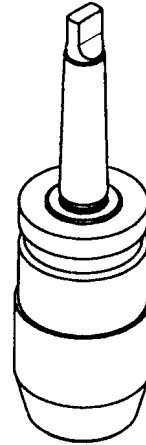
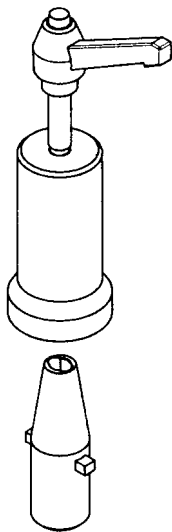
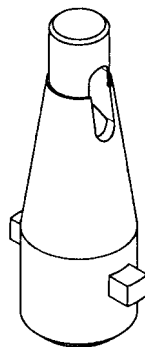
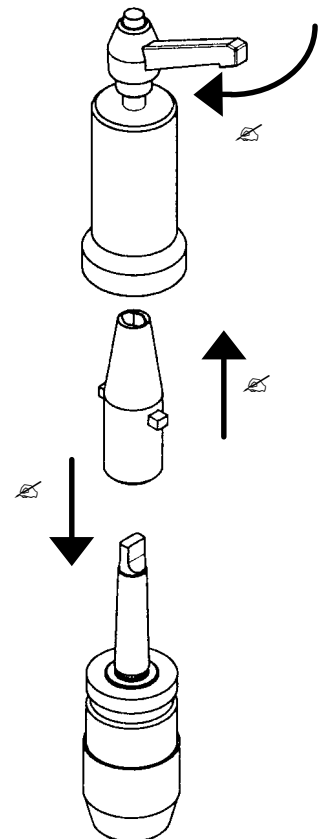

PRODUIT: OUTILLAGE
PRODUCT: TOOLING**OBJET: ADAPTATEURS POUR CONE MORSE N°2**
SUBJECT: ADAPTORS FOR MORSE TAPER No 2

The adaptors for Morse tapers number 2 allow fitting the spindle of the SERDI seat cutting machines with Morse tapers number 2 tools for drilling, tapping or reaming. For example, **SERDI 3100**: precision chuck.

**MILLENIUM 3.0****SERDI 3250**
Ref. 012210**SERDI 60 / 80 / 100****SERDI 3200**
Ref. 404115

With our new SERDI MILLENIUM 3.0, **SERDI 3250**: adaptor for Morse taper number 2 with its extractor is to be used.

**Using the extractor:**

- ✍ Fit the extractor on the assembly adaptor + Morse taper tool.
- ✍ Screw the handle until ...
- ✍ the parts separate.