

PRODUIT: SURFACEUSES
GMA/GMP 1300 - GP 1000
PRODUCT: SURFACE GRINDERS

OBJET: SERRAGE DES SEGMENTS DE MEULE
SUBJECT: CLAMPING OF THE GRINDING
SEGMENTS

Because of the variance in the grinding segments width, smaller segments might not be clamped properly onto the segment holder / grinding wheel.

We noticed on few cases that the wedged clamp holding the segment might contact the grinding wheel before the grinding segment gets securely fastened.

SERDI recommends to replace the wedged clamps on all surface grinders in operation. A free of charge replacement kit is available.

The tightening screws remain the same.

Make sure to double check the balance of the grinding wheel after reassembly, and adjust the balancing counterweights accordingly.

Kit reference : **013126** including:
5 wedged clamps **013249.**
5 star washers **012762.**

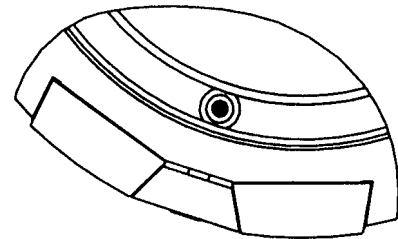
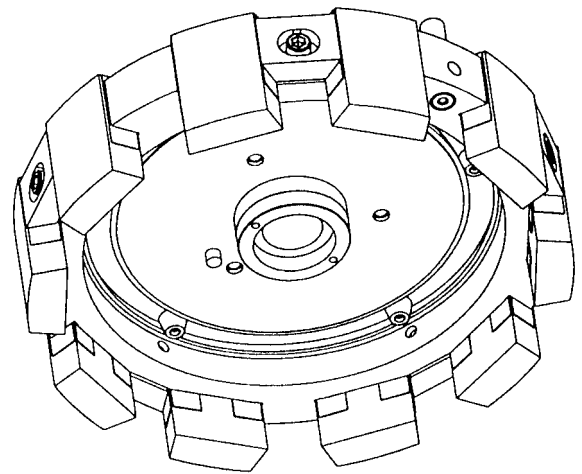

THIS APPLIES TO ALL MACHINES PRIOR TO SERIAL # 234 / 1997